

GPS MODULE

51 CHANNELS
26 X 26 MM SIZE
2MM DIP HEADERS
PATCH ANTENNA ON TOP
3.3V OPERATION
TTL SERIAL INTERFACE

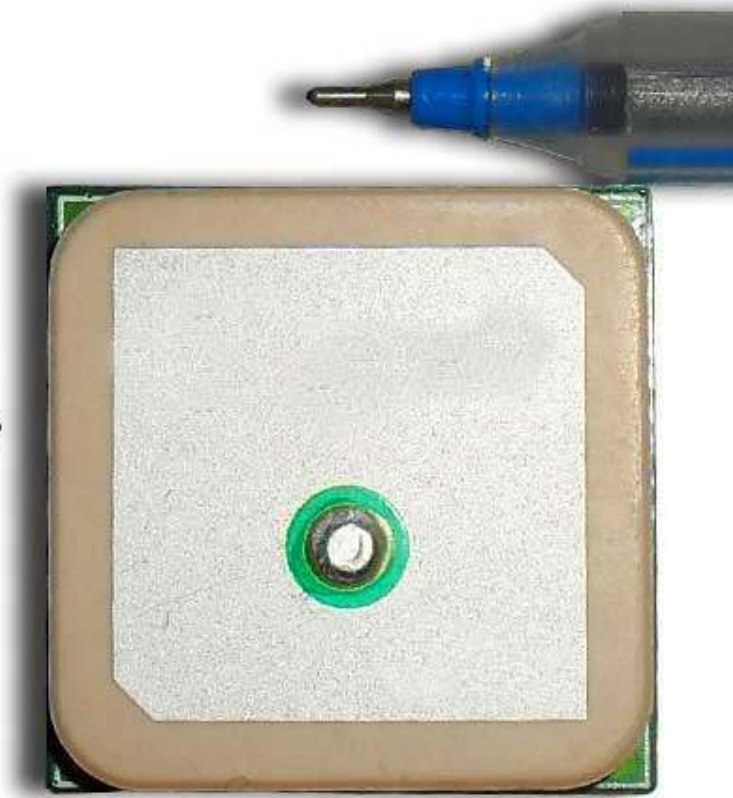

51-channel GPS Engine Board Smart Antenna

ROBOKITS GPS 01

<http://www.robokits.co.in>

<http://www.robokitsworld.com>

Robokits GPS 01

Description

The ROBOKITS GPS 01 is a POT (Patch On Top) GPS the third generation module. This POT GPS receiver providing a solution that high position and speed accuracy performances as well as high sensitivity and tracking capabilities in urban conditions. The GPS chipsets inside the module are designed by MediaTek Inc., which is the world's leading digital media solution provider and largest fab-less IC company in Taiwan. The module can support up to 51 channels. The GPS solution enables small form factor devices. They deliver major advancements in GPS performances, accuracy, integration, computing power and flexibility. They are designed to simplify the embedded system integration process.

Features

- Based on MediaTek Single Chip Architecture.
- Dimension : 26mm x 26mm x 11.7mm
- Patch Antenna Size : 25mm x 25mm x 4mm
- Low Power Consumption : 55mA @ acquisition, 40mA @ tracking
- L1 Frequency, C/A code, 51-channel
- High Sensitivity : Up to -158 dBm tracking, superior urban performances¹
- Position Accuracy : Without aid: 3m 2D-RMS
DGPS(RTM,SBAS(WAAS,EGNOS,MASA)):2.5m 2D-RMS
- Cold Start is Under 36 seconds (Typical)¹
- Warm Start is Under 34 seconds (Typical)¹
- Hot Start is Under 1 second (Typical)¹
- Data output Baud rate : **9600 bps(Default)**
- Max. Update Rate : 5Hz (**Default: 1 Hz**)
- Pin header Connection for easy to assemble
- RoHS Compliant

¹ Reference to GPS chipset specification

System Block

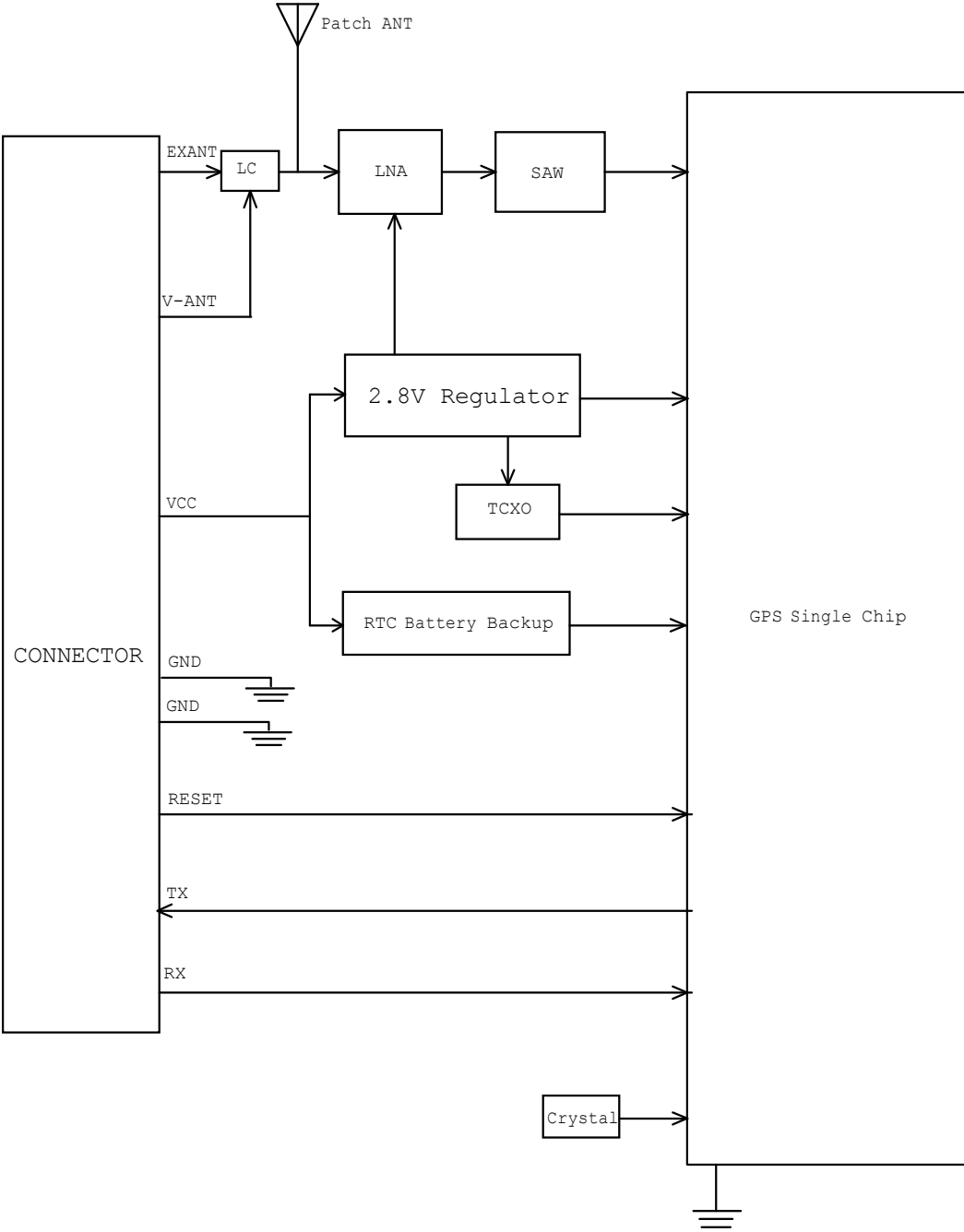

Mechanical and Pin Configuration

Item	Model Name	Description
1	ROBOKITS GPS	Pin Header, Dual Row, SMT TYPE

1. Model Name: ROBOKITS GPS 01

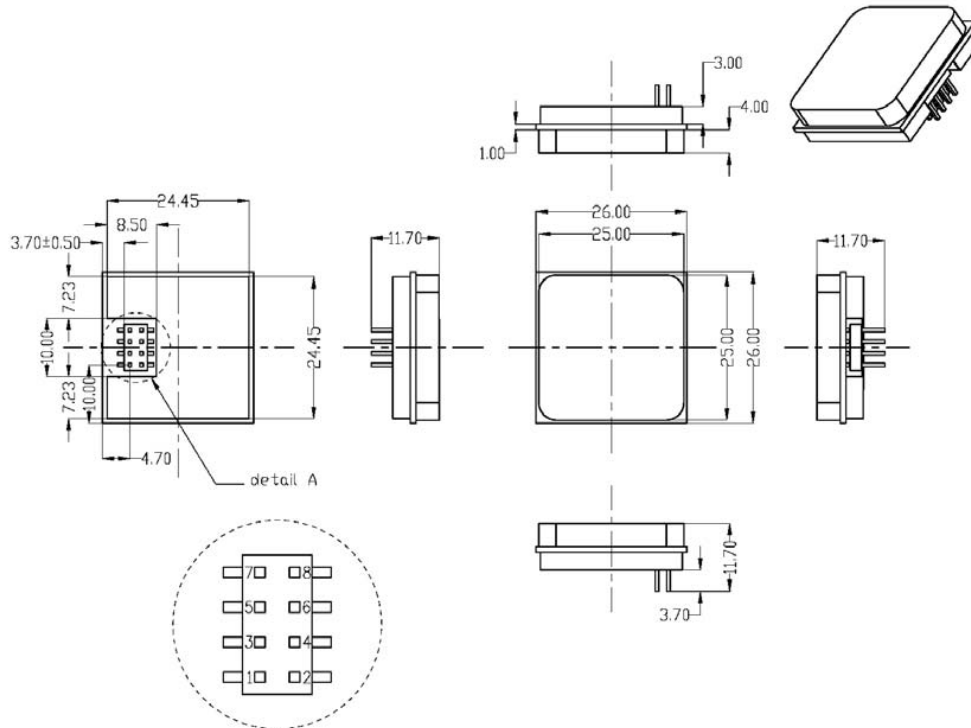

Detail A (Please refer to Appendix A)

Pin Definition

Pin	Name	I/O	Description
1	VCC	P	DC Power Input
2	GND	P	Ground
3	RX	I	Serial Data Input
4	TX	O	Serial Data Output
5	V-ANT	P	External Antenna power input
6	GND	P	Ground
7	RESET	I	Reset
8	EXANT	I	External Antenna input

Description of I/O Pin

VCC (Pin1)

The main DC power supply is DC 3.3V±5% for the module.

GND (Pin2)

The analog ground and digital ground for the module.

RX (Pin3)

This is the UART receiver of the module. It is used to receive software commands and firmware update.

TX (Pin4)

This is the UART transmitter of the module. It outputs the GPS information for application.

V-ANT (Pin5)

The power supply is DC 2.7V to 3.3V for the External Antenna input pin(Pin8).

The maximum consumption current for the GPS antenna is limited to 30mA.

GND(Pin6)

The analog ground and digital ground for the module.

RESET(Pin7)

This pin is Reset pin, the pin is active Low, the pin will keep high when power on. If you don't want to control the pin , please keep no connection (N/C)

EXANT(Pin8)

This pin is External Antenna input pin.

Specifications

General	
Chipset	MTK MT3318
Frequency	L1, 1575.42MHz
C/A Code	1.023 MHz
Channels	51 channels
DGPS	RTCM protocol WAAS, EGNOS, MSAS
Datum	WGS84(Default), Tokyo-M, Tokyo-A, User Define
CPU	ARM7TDMI
Dimensions	
Length/Width/Height	26mm x26mm x 11.7mm
Weight	12.5g
Performance Characteristics	
Position Accuracy	Without aid: 3m 2D-RMS
	DGPS(RTM,SBAS(WAAS,EGNOS,MASA)):2.5m 2D-RMS
Velocity Accuracy	Without aid : 0.1 m/s
	DGPS (RTCM, SBAS (WAAS, EGNOS, MSAS)) : 0.05m/s
Acceleration	Without aid : < 4g
	DGPS (RTCM, SBAS (WAAS, EGNOS, MSAS)) : < 4g
Timing Accuracy	100 ns RMS
Sensitivity¹	Acquisition : -146dBm (Cold Start)
	Reacquisition : -156dBm
	Tracking : -158dBm
Max. Update Rate	5Hz (Default: 1 Hz)

Acquisition (Open sky, stationary)	
Reacquisition Time ¹	Less than 1 second
Hot start ¹	1 second (Typical)
Warm start ¹	34seconds (Typical)
Cold start ¹	36 seconds (Typical)
Dynamic	
Altitude	Maximum 18,000m
Velocity	Maximum 515m/s
Acceleration	Maximum 4g
I/O	
Signal Output	8 data bits, no parity, 1 stop bit
Available Baud Rates	9600 bps(Default) ,4800/9600/14400/19200/38400/57600/ 115200 is also available
Protocols	NMEA 0183 v3.01, MTK NMEA Command
Data output Interface	
Protocol messages	9600 bps/8/N/1 (Default)
Output format (Default)	GGA(1sec),GSA(1sec),RMC(1sec),VTG(1sec),GSV(5sec)
Environment	
Operating Temperature	-40°Cto 85 °C(without coin battery) -20°Cto 60 °C(with coin battery)
Storage Temperature	-50°Cto 90 °C(without coin battery) -20°Cto 60 °C(with coin battery)
Operating Humidity	5% to 95% (no condensing)

¹ Reference to GPS chipset specification

Recommendation External Antenna Specification

MODEL: ROBOKITS GPS	
Center Frequency fo	1575.42MHz ± 2MHz
Bandwidth (min.)	9MHz
Operating Temperature	-40 ~ +85°C
Storage Temperature	-50 ~ +120°C
Relative Humidity	0% ~ 100%
Antenna + Pre-amplifier:	
System Gain at fo Without Cable Loss	30dBi at 90° Zenith
Output VSWR at fo (max.)	2
Impedance (typ.)	50ohm
Cable Loss RG-174/3,5,10meters at fo (typ.)	4dB, 7dB, 14dB
Mounting	Magnet
Patch Antenna:	
Polarization	R.H.C.P.
Gain at fo (typ.)	3dBi at Zenith
VSWR at fo (max.)	2
Impedance (typ.)	50ohm
Pre-amplifier:	
Gain at fo	27dB ± 1dB
Noise Figure at fo (typ.)	1.15dB
VSWR at fo (max.)	2
Impedance (typ.)	50ohm
Input Voltage	2.7V ~ 3.6V
Current Consumption (typ.)	18mA@3V

Test Environment Condition : 25°C/60RH

DC Characteristics

Parameter	Condition	Min.	Typ.	Max.	Unit
Operation supply Voltage	VCC	3.135	3.3	3.465	V
Operation supply Ripple Voltage	-	-	-	50	mVpp
RXA TTL H Level	VCC=5.0V	2.1	-	VCC	V
RXA TTL L Level	VCC=5.0V	0	-	0.9	V
TXA TTL H Level	VCC=5.0V	2.1	-	2.8	V
TXA TTL L Level	VCC=5.0V	0	-	0.8	V
Backup Battery Voltage	-	-	3.0	-	V
Power Consumption @ 3.3V	Acquisition	50	55	60	mA
	Tracking	35	40	45	mA

NMEA Output Sentence

Table-1 lists each of the NMEA output sentences specifically developed and defined by MTK for use within MTK products

NMEA Output Sentence		Table-1
Option	Description	
GGA	Time, position and fix type data.	
GSA	GPS receiver operating mode, active satellites used in the position solution, and DOP values.	
GSV	The number of GPS satellites in view satellite ID numbers, elevation, azimuth, and SNR values.	
RMC	Time, date, position, course and speed data. Recommended Minimum Navigation Information.	
VTG	Course and speed information relative to the ground.	

GGA—Global Positioning System Fixed Data. Time, Position and fix related data for a GPS receiver

Table-2 contains the values for the following example :

\$GPGGA,035238.000,2307.1219,N,12016.4423,E,1,9,0.89,23.6,M,17.8,M,,*69

GGA Data Format				Table-2
Name	Example	Units	Description	
Message ID	\$GPGGA		GGA protocol header	
UTC Time	035238.000		hhmmss.sss	
Latitude	2307.1219		ddmm.mmmm	
N/S Indicator	N		N=north or S=south	
Longitude	12016.4424		dddmm.mmmm	
E/W Indicator	E		E=east or W=west	
Satellites Used	9		Range 0 to 14	
HDOP	0.89		Horizontal Dilution of Precision	

MSL Altitude	17.3	meters	Antenna Altitude above/below mean-sae-level
Units	M	meters	Units of antenna altitude
Geoidal Separation	17.8	meters	
Units	M	meters	Units of geoidal separation
Age of Diff. Corr.		second	Null fields when DGPS is not used
Checksum	*69		
<CR> <LF>			End of message termination

GSA—GNSS DOP and Active Satellites

Table-3 contains the values for the following example :

\$GPGSA,A,3,29,21,09,18,10,26,12,24,15,,,,,1.20,0.89,0.80*04

GSA Data Format			Table-3
Name	Example	Units	Description
Message ID	\$GPGSA		GSA protocol header
Mode 1	A		See Table-4
Mode 2	3		See Table-5
Satellite Used	29		SV on Channel 1
Satellite Used	21		SV on Channel 2
....
Satellite Used			SV on Channel 12
PDOP	1.20		Position Dilution of Precision
HDOP	0.89		Horizontal Dilution of Precision
VDOP	0.80		Vertical Dilution of Precision
Checksum	*04		
<CR> <LF>			End of message termination

Mode 1		Table-4
Value	Description	
M	Manual—forced to operate in 2D or 3D mode	
A	2D Automatic—allowed to automatically switch 2D/3D	

Mode 2		Table-5
Value	Description	
1	Fix not available	
2	2D (< 4 SVs used)	
3	3D (\geq 4 SVs used)	

GSV—GNSS Satellites in View

Table-7 contains the values for the following example :

\$GPGSV,3,1,10,24,76,195,48,09,62,173,48,21,50,308,48,15,45,021,48*73

\$GPGSV,3,2,10,26,33,031,46,18,29,319,46,10,21,092,45,29,18,221,44*7D

\$GPGSV,3,3,10,12,05,167,24,05,03,181,*76

GSV Data Format				Table-6
Name	Example	Units	Description	
Message ID	\$GPGSV		GSV protocol header	
Number of Messages	3		Range 1 to 3 <i>(Depending on the number of satellites tracked, multiple messages of GSV data may be required.)</i>	
Message Number1	1		Range 1 to 3	
Satellites in View	10			
Satellite ID	24		Channel 1 (Range 1 to 32)	
Elevation	76	degrees	Channel 1 (Maximum 90)	
Azimuth	195	degrees	Channel 1 (True, Range 0 to 359)	
SNR (C/No)	48	dBHz	Range 0 to 99, (null when not tracking)	
....	

Satellite ID	15		Channel 4 (Range 1 to 32)
Elevation	45	degrees	Channel 4 (Maximum 90)
Azimuth	021	degrees	Channel 4 (True, Range 0 to 359)
SNR (C/No)	48	dBHz	Range 0 to 99, (null when not tracking)
Checksum	*73		
<CR> <LF>			End of message termination

RMC—Recommended Minimum Navigation Information

Table-7 contains the values for the following example :

\$GPRMC,035242.000,A,2307.1220,N,12016.4420,E,0.06,0.00,140508,,A*63

RMC Data Format			Table-7
Name	Example	Units	Description
Message ID	\$GPRMC		RMC protocol header
UTC Time	035242.000		hhmmss.sss
Status	A		A=data valid or V=data not valid
Latitude	2307.1220		ddmm.mmmm
N/S Indicator	N		N=north or S=south
Longitude	12016.4420		dddmm.mmmm
E/W Indicator	E		E=east or W=west
Speed Over Ground	0.06	knots	
Course Over Ground	0.00	degrees	True
Date	140508		ddmmyy
Magnetic Variation		degrees	E=east or W=west <i>(Need Global Top customization service)</i>
Mode	A		A= Autonomous mode

			D= Differential mode E= Estimated mode
Checksum	*63		
<CR> <LF>			End of message termination

VTG—Course and speed information relative to the ground.

Table-8 contains the values for the following example :

\$GPVTG,0.00,T,,M,0.06,N,0.11,K,A*3B

VTG Data Format			Table-8
Name	Example	Units	Description
Message ID	\$GPVTG		VTG protocol header
Course	0.00	degrees	Measured heading
Reference	T		True
Course		degrees	Measured heading
Reference	M		Magnetic <i>(Need Global Top customization service)</i>
Speed	0.06	knots	Measured horizontal speed
Units	N		Knots
Speed	0.11	km/hr	Measured horizontal speed
Units	K		Kilometers per hour
Mode	A		A= Autonomous mode D= Differential mode E= Estimated mode
Checksum	*3B		
<CR> <LF>			End of message termination

MTK NMEA Command Protocol

Packet Type :

103 PMTK_CMD_COLD_START

Packet Meaning :

Cold Start : Don't use Time, Position, Almanacs and Ephemeris data at re-start.

Example : \$PMTK103*30<CR><LF>

ESD Handling



Please carefully follow the following precautions to prevent severe damage to GPS modules.

GlobalTop GPS modules are sensitive to electrostatic discharges, and thus are Electrostatic Sensitive Devices (ESD). Careful handling of the GPS modules and in particular to its patch antenna (if included) and RF_IN pin or connector, must follow the standard ESD safety practices:

Unless there is a galvanic coupling between the local GND and the PCB GND, then the first point of contact when handling the PCB shall always be between the local GND and PCB GND.

Before working with RF_IN pin or connector, please make sure the GND is connected

When working with RF_IN pin or connector, do not contact any charges capacitors or materials that can easily develop or store charges such as patch antenna, coax cable, soldering iron.

Please do not touch the mounted patch antenna to prevent electrostatic discharge from the RF input.

Appendix A:

Ps. The module use 4 contacts per row.

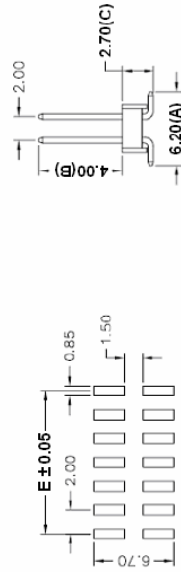
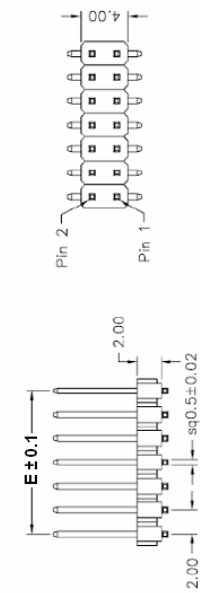

MATERIAL
 Contact Pin: Brass

SPECIFICATION
 Current Rate: 1 AMP
 Insulation Resistance: 5000MΩ Min. at DC 500V
 Contact Resistance: 20mΩ Max. at DC 100mA
 Dielectric Voltage: AC 500V for one minute
 Operation Temperature: - 40°C to + 105°C

PH2M20-204-GB-LF+CAP-I-6.2/4.0/2.7
 1 2 3 4 5 6 7 8 9

1. Pitch=2.0 mm
2. M : SMT Type
3. Height=2.0mm
4. No. of contacts per row
5. G : Gold flash
6. B : Black Insulator
7. LF : Lead Free
8. T : 管装
9. DIM A/B/C=6.2/4.0/2.7

Recommended P.C.B Layout

Poles	DIM E	Poles	DIM E	Poles	DIM E	Poles	DIM E	Poles	DIM E	Poles	DIM E
2	2.00	9	16.00	16	30.00	23	44.00	30	58.00	37	72.00
3	4.00	10	18.00	17	32.00	24	46.00	31	60.00	38	74.00
4	6.00	11	20.00	18	34.00	25	48.00	32	62.00	39	76.00
5	8.00	12	22.00	19	36.00	26	50.00	33	64.00	40	78.00
6	10.00	13	24.00	20	38.00	27	52.00	34	66.00	41	80.00
7	12.00	14	26.00	21	40.00	28	54.00	35	68.00	42	82.00
8	14.00	15	28.00	22	42.00	29	56.00	36	70.00	43	84.00
										44	86.00
										45	88.00
										46	90.00
										47	92.00
										48	94.00
										49	96.00
										50	98.00